

TECHNICAL SPECIFICATIONS

T1300 H

TECNA®

Breaker code

Rev.

Year

T13000

2.0

2016

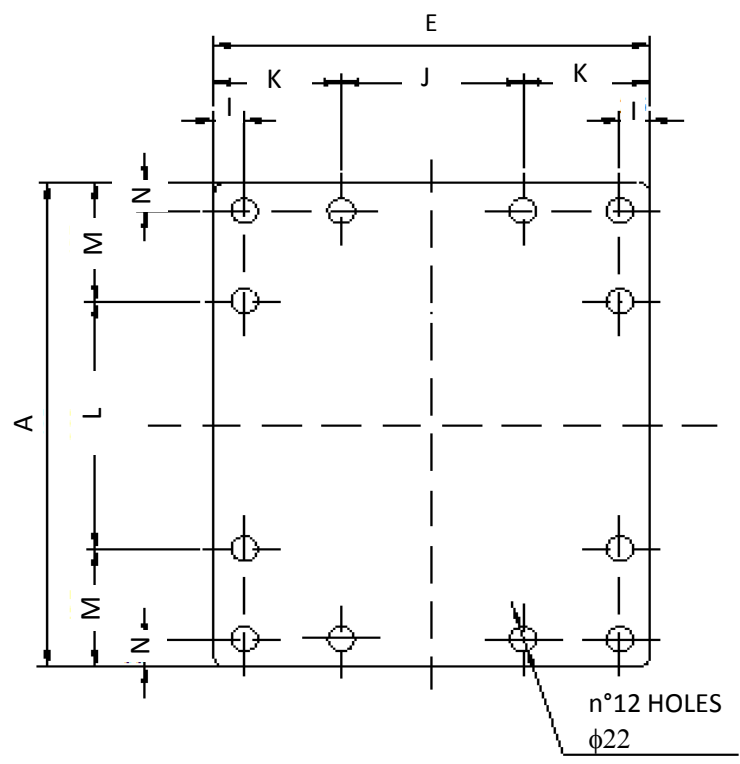
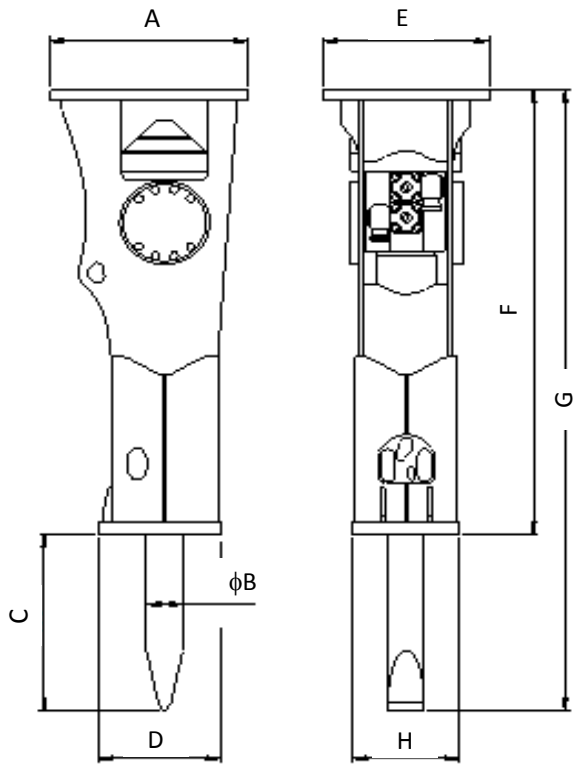

Min. Plate thickness: 35 mm (1,4 in)

	mm	in		mm	in
A	560	22,0	H	306	12,0
φ B	120	4,7	I	25	1,0
C	511	20,1	J	190	7,5
D	370	14,6	K	125	4,9
E	440	17,3	L	310	12,2
F	1631	64,2	M	125	4,9
G	2142	84,3	N	25	1,0

I	GB	E	D	METRIC UNIT / IMPERIAL UNIT			
PESO ESCAVATORE	SUITABLE EXCAVATOR	PESO EXCAVADORA	GEEIGNET FÜR TRÄGERGERÄT	16 ÷ 24	Ton	35274 ÷ 52911	lbs
PESO MEDIO OPERATIVO	OPERATING WEIGHT	PESO MEDIO OPERATIVO	ARBEITSGEWICHT DES HAMMERS	1300	Kg	2866,0	lbs
DIAMETRO UTENSILE	TOOL DIAMETER	DIAMETRO PICA	MEISSEL DURCHMESSER	120	mm	4,72	in
PORTATA	OIL SUPPLY	CAUDAL	ÖLBEDARF	120 ÷ 150	l/min	32 ÷ 40	GPM
PRESSIONE DI LAVORO	BREAKER WORKING PRESSURE	PRESSION EN EL MARTILLO	ARBEITSSOLDRUCK IM HYDRAULIKHAMMER	130 ÷ 160	bar	1885 ÷ 2321	PSI
PRESSIONE REGOLATA ALL'ESCAVATORE	RELIEF PRESSURE SETTING	PRESSION EN LA EXCAVADORA	ARBEITSSOLDRUCK IM TRÄGERGERÄT	200	bar	2901	PSI
CONTROPRESSIONE MAX	MAX BACK PRESSURE	CONTRAPRESSION MAX	MAX STAUDRUCK	15	bar	218	PSI
POTENZA INGRESSO (MAX)	INPUT POWER (MAX)	POTENCIA DE ENTRADA (MAX)	EINGANGS LEISTUNG (MAX)	32	Kw	42,9	HP
CLASSE DI ENERGIA D'URTO	IMPACT ENERGY CLASS	ENERGIA DE IMPACTO CLASE	KLASSE SCHLAGENERGIE	2880	J	2125	Ft/lbs
NUMERO DI COLPI AL MINUTO	IMPACT RATE	GOLPES MINUTO	SCHLAGZAHL PRO MINUTE	450 ÷ 600	BPM	450 ÷ 600	BPM
TEMPERATURA MAX OLIO IDRAULICO	MAX TEMPERATURE HYDRAULIC OIL	TEMP. MAX DE ACEITE HIDRAULICO	MAX ÖLTEMPERATUR	80	°C	176	°F
TUBAZIONE IMPIANTO MANDATA (Ø min.)	RECOMMENDED INLET LINE SIZE (Ø min.)	TUBERIA INSTALACION PRESION (Ø min.)	EMPFOHLENE VORLAUF LEITUNG (Ø min.)	24	mm	0,94	in
TUBAZIONE IMPIANTO RITORNO (Ø min.)	RECOMMENDED RETURN LINE SIZE (Ø min.)	TUBERIA INSTALACION RITORNO (Ø min.)	EMPFOHLENE RUECKL. LEITUNG (Ø min.)	32	mm	1,26	in
LUNGHEZZA CONSIGLIATA TUBI FLESSIBILI	SUGGESTED MIN FLEX HOSES LENGTH	LONGITUD MAXIMA LATIGUILLO	LÄNGE HAMMER ANSCHLUSS SCHLAUCH	2400	mm	94,5	in
ATTACCO INGRESSO DEMOLITORE	HOSE CONNECTION AT THE BREAKER'S INLET LINE	RACOR PRESSION MARTILLO	HAMMER SCHLAUCH RÜCKLAUF	1" G		1" G	
ATTACCO USCITA DEMOLITORE	HOSE CONNECTION AT THE BREAKER'S RETURN LINE	RACOR RITORNO MARTILLO	HAMMER SCHLAUCH VORLAUF	1" G		1" G	